



ZS6HVB

Affiliated to the  
SARL

# SHACKNEWS

## HIGHVELD AMATEUR RADIO CLUB

### Third Quarter 2016

We're on



### COMMUNICATION IS THE NAME OF THE GAME

It is proposed to hold the September meeting at the home of Doug and Merle on the 17<sup>th</sup> September.

This meeting is also the AGM.

Doug is currently in hospital and hopefully will be coming home today- 5-9-16.

If there is a change in venue it will be communicated before hand.

---

**In a Podiatrist's office: .... "Time wounds all heels."**

**On a Septic Tank Truck: .....Yesterday's Meals on Wheels**

**At an Optometrist's Office:**

**"If you don't see what you're looking for, ..... You've come to the right place."**

**On a Plumber's truck: "We repair what your husband fixed."**

**On another Plumber's truck: ..... "Don't sleep with a drip. Call your plumber."**

**At a Tire Shop: ..... "Invite us to your next blowout."**

**On an Electrician's truck: ..... "Let us remove your shorts."**

**On a Maternity Room door: ..... "Push. Push. Push."**

**At a Car Dealership: ...."The best way to get back on your feet - miss a car payment."**

**In a Veterinarian's waiting room: ..... "Be back in 5 minutes. Sit! Stay!"**

**In a Restaurant window: .."Don't stand there and be hungry; Come on in and get fed up."**

**In the front yard of a Funeral Home: .... "Drive carefully. We'll wait."**

---

# Some interesting antennas found here

[http://www.qsl.net/va3iul/Antenna/Wire%20Antennas%20for%20Ham%20Radio/Wire\\_antennas\\_for\\_ham\\_radio.htm](http://www.qsl.net/va3iul/Antenna/Wire%20Antennas%20for%20Ham%20Radio/Wire_antennas_for_ham_radio.htm)

Some examples

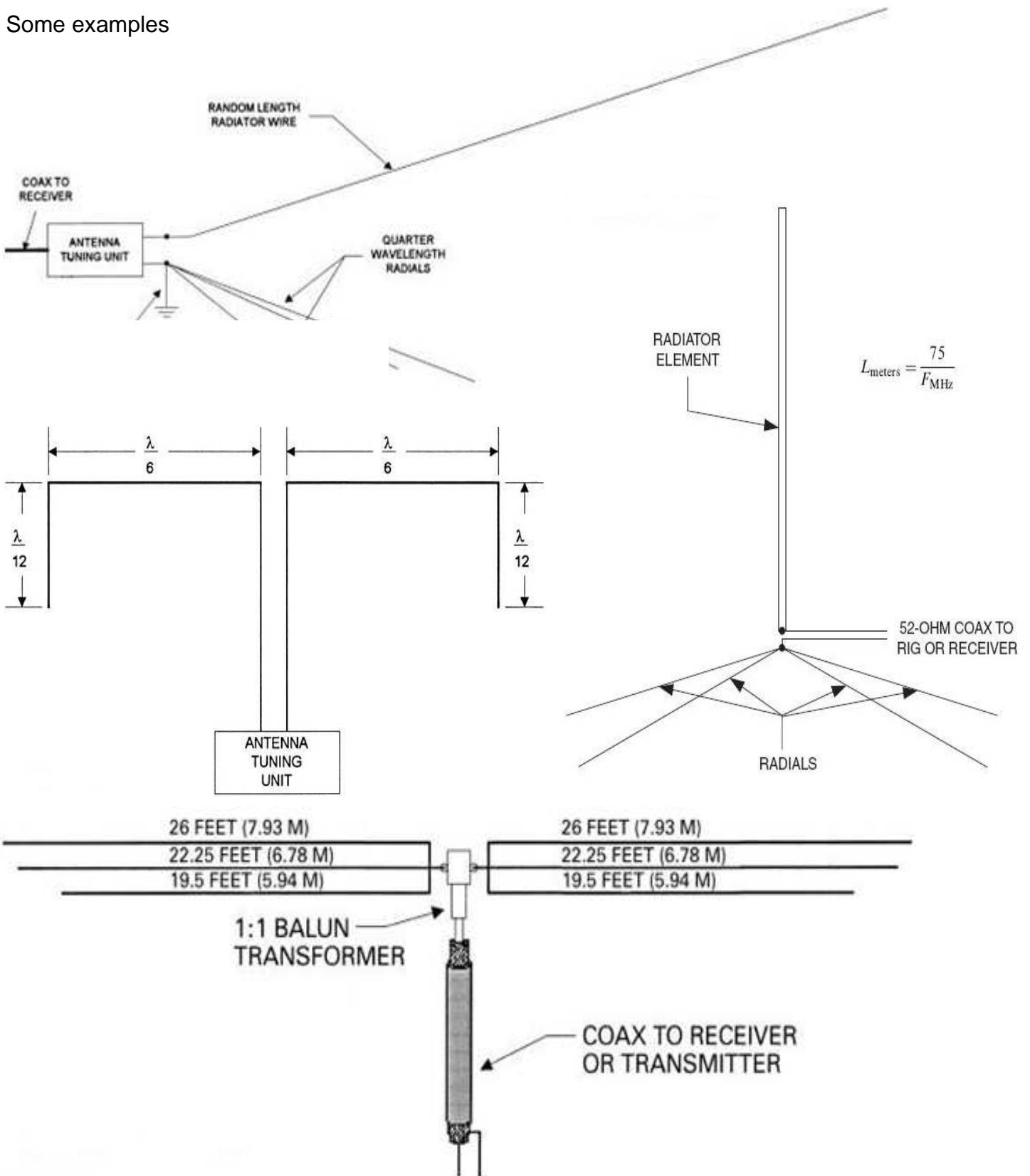

## Test for live wires in a wall

This little circuit will help you to scan the line of a 220V live wire in the wall. The FET gate is connected to a capacitive metal sensor (which is usually a simple metal plate). When you hold the sensor close to the wall, the LED will indicate the current flow around where it detects the wire. Works on 9VDC.

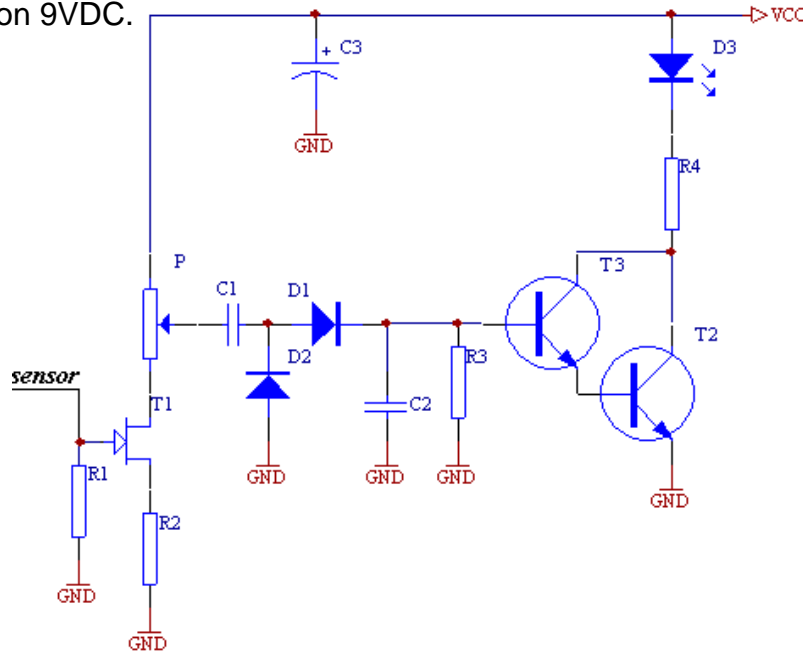

### Components

R1	15M
R2	1.8k
R3	1M
R4	470
P	10k
D1	1N4148
D2	1N4148
D3	LED
C1	2.2u
C2	100n
C3	22u
T1	BF244
T2	BC182B
T3	BC182B

## Pulse width Modulation using a 555

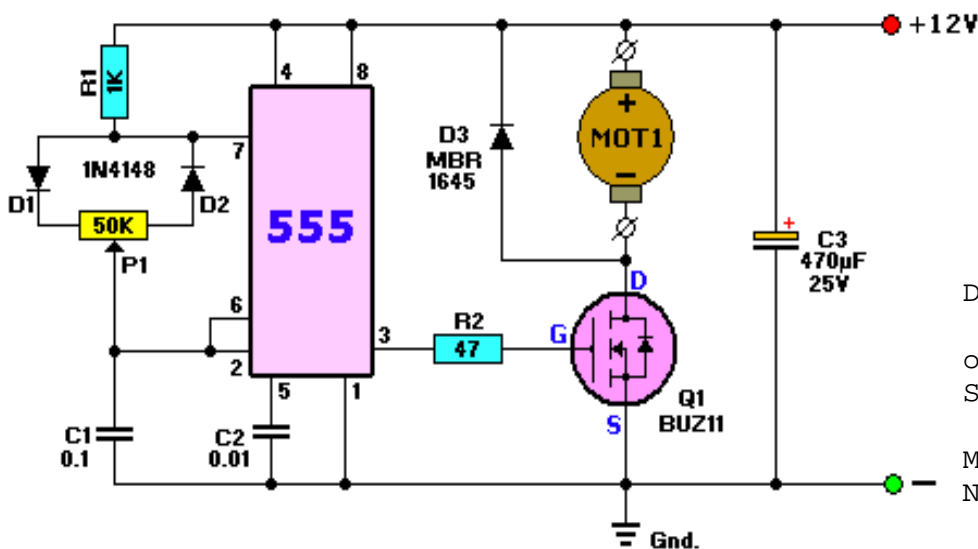

### Components

R1	= 1K
R2	= 47 ohm
P1	= 50K potentiometer
C1	= 0.1uF, (100nF),
C2	= 0.01uF, (10nF)
C3	= 470uF, 25V,
D1, D2	= 1N4148,
D3	= MBR1645, NTE6081,
	or similar. 45V/16A
Q1	= BUZ11, NTE2389,
	MosFET, High Speed Switch,
	N-channel, 30V/35A
IC1	= NE555,

This circuit is capable of regulating 12V motors and DC light bulbs. No heatsink required for Q1 or D3 if the current does not exceed 2A. If it does, a sufficient heatsink for both the Schottky Diode (D3) and MosFET Q1 is required.

The regulation is obtained via PWM or Pulse Width Modulation. The output pin 3 of the 555 provides square-wave with an adjustable duty-cycle. What that basically means is that the pulse width changes the speed of the motor. The output from the 555 feeds the mosfet via current limiting resistor R2 of 47 ohms. Because the MosFET Q3 only "switches" and is not behaving like a pot, its energy-waste level is negligible, and also provides the motor more coupling at low rpm. The maximum current Q1 can provide (safely) is about 10A. The replacement type mentioned in the parts list (NTE2389 can provide up to 35A at 60V. I use a cpu-cooler-fan for additional cooling at high rpm.



Don't worry, he's on a leash.



"Each capsule contains your medication, plus a treatment for each of its side effects."



Do you want yours licked or not licked?

Just kidding, they're all licked.



I've been calling you all day.

That's a calculator.

### Club Information

**Postal address** PO Box 19937 Sunward Park 1470

**Website** <http://www.zs6hvb.za.net>

**Back Issues of Shacknews available on the club website**

**e-mail** [zs6hvb@zs6hvb.za.net](mailto:zs6hvb@zs6hvb.za.net)

**Repeater** 145.1875 MHz input - 145.7875 MHz output

**Bulletins** Sunday morning - 145.7875 MHz & 7162 KHz @ 08h45.

Monthly meeting venue  
Every Third month  
On the 3rd Saturday of the month  
at 14:30.  
@ various venues

		Committee	
Chairman	Vacant		
Secretary/Treasurer	Berridge Emmett	ZS6BFL	011-893-1291
Shacknews Editor	Berridge Emmett	ZS6BFL	011-893-1291
Shacknews Printing	Harry Lautenbach	ZS6LT	011-888-5362