



SHACKNEWS

HIGHVELD AMATEUR RADIO CLUB

DECEMBER 2007



COMMUNICATION IS THE NAME OF THE GAME

A merry Christmas and happy 2008 to all members

Meeting There was no official meeting held this month. Instead the annual end-of-year braai combined with the SSC club was held at the QTH of Rex and Ingrid. This was in the form of a spit braai and there was also a open wood braai for those who wanted braai their own piece of meat. Thanks go to Rex and Ingrid for the use of their property, tables, chairs and weather etc. To Doug who organized and collected the spit braai and meat. Also to Yvonne who arranged, prepared and cooked the various veggies in the trays at the bottom of the spit braai as well as attending to the meat. Another thanks to all the ladies who brought along many various salads. Nobody ate any supper that evening from what was heard on the repeater the following morning.

The first meeting for 2008 will be held on Saturday 2nd February. Members from the AWA will be visiting.

SSC Meeting The first meeting of the new year will be held at the home of Berridge and Sandra on the 12th of January 2008



I'd love to be eight again

A man asked his wife what she'd like for her birthday.

'I'd love to be eight again' she replied.

On the morning of her birthday, he arose early and made her a bowl of Coco Pops and jammy toasties!

He took her to Alton Towers and put her on every ride in the park:

- * The Death Slide
- * The Wall of Fear
- * The Screaming Monster Roller Coaster

Five hours later she staggered out of the theme park. Her head was reeling and her stomach felt upside down. Right away they journeyed to a McDonalds where her loving husband ordered her a Happy Meal with extra fries and a refreshing chocolate milk shake .

Then it was off to the movies: the latest Kiddies three hour epic cartoon, a hot dog, popcorn, all the Coke she could drink, her favourite lolly and M&Ms
What a fabulous adventure!

Finally she wobbled home with her husband and collapsed onto the bed exhausted. He leaned over his precious wife with a big smile and lovingly asked 'Well dear, what was it like being eight again?'

Her eyes slowly opened and her expression changed to one of total realisation...'I meant my dress size, you idiot !!!'

The moral of this story: Even when a man is listening, he's still gonna get it wrong.

A pre-amp for dynamic microphones

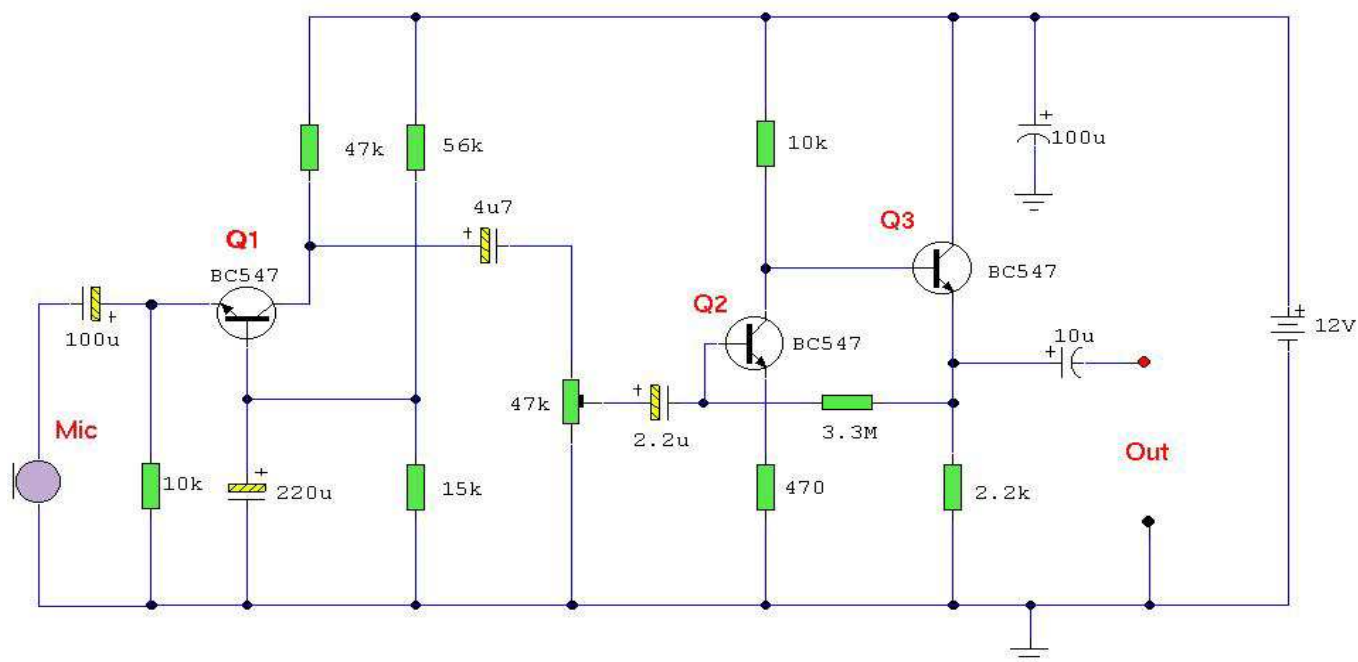

Description:

A low noise pre-amplifier suitable for amplifying dynamic microphones with 200 to 600 ohm output impedance.

This is a 3 stage discrete amplifier with gain control. Alternative transistors such as BC109C, BC548, BC549, and BC549C may be used with little change in performance. The first stage built around Q1 operates in common base configuration. This is unusable in audio stages, but in this case, it allows Q1 to operate at low noise levels and improves overall signal to noise ratio. Q2 and Q3 form a direct-coupled amplifier.

As the signal from a dynamic microphone is low typically much less than 10mV, then there is little to be gained by setting the collector voltage of Q1 to half the supply voltage. In power amplifiers, biasing to half the supply voltage allows for maximum voltage swing, and highest overload margin, but where input levels are low, any value in the linear part of the operating characteristics will suffice. Here Q1 operates with a collector voltage of 2.4V and a low collector current of around 200uA. This low collector current ensures low noise performance and also raises the input impedance of the stage to around 400 ohms. This is a good match for any dynamic microphone having impedances between 200 and 600 ohms. The output impedance at Q3 is low.



For all DX happenings try the following URLs

<http://www.ng3k.com/Misc/adxo.html>

<http://www.ng3k.com/Contest/>

<http://www.ng3k.com/Dxcc/>

A Complete Solar Cycle from SOHO

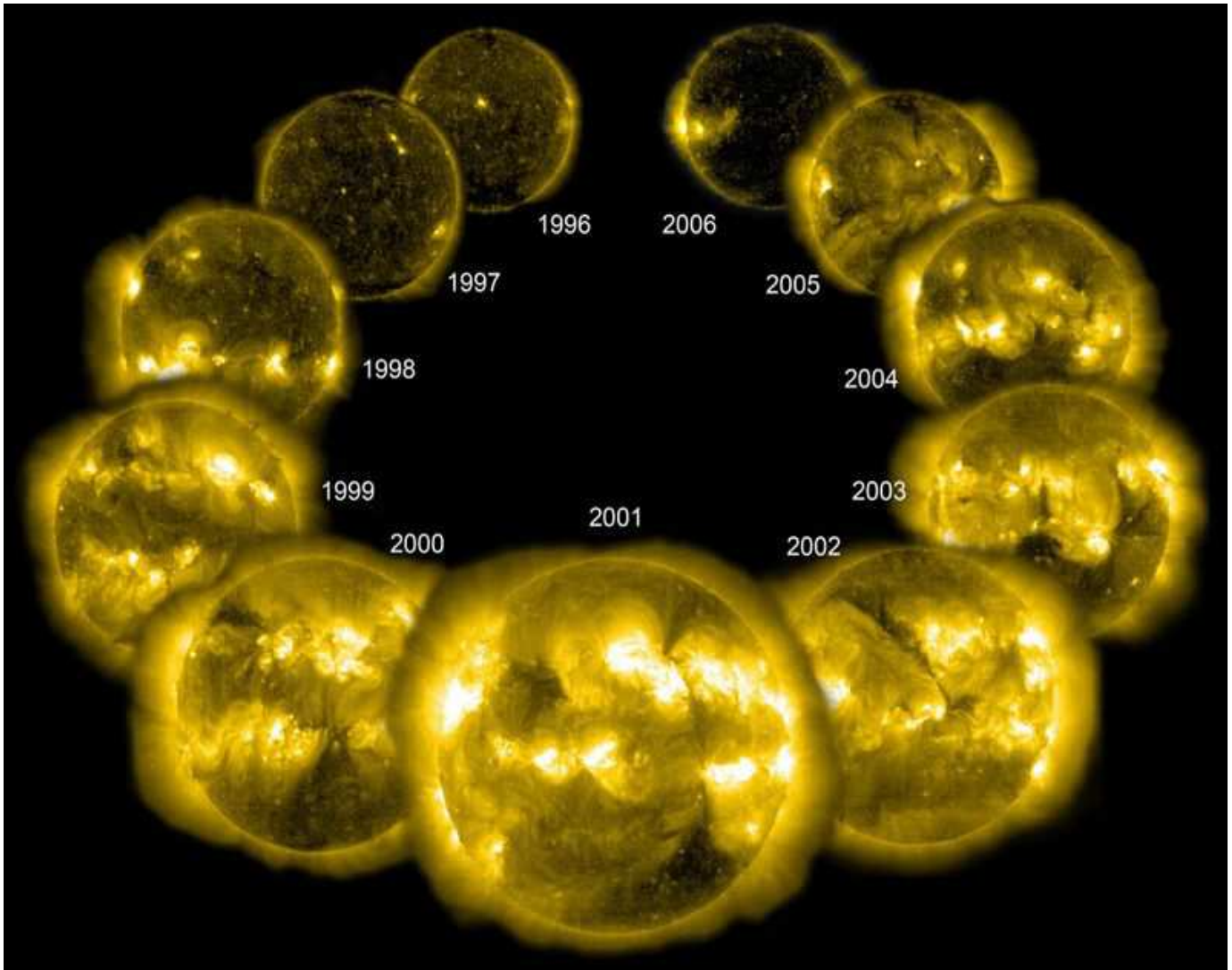

Every eleven years, our Sun goes through a solar cycle. A complete solar cycle has now been imaged by the sun-orbiting SOHO spacecraft. A solar cycle is caused by the changing magnetic field of the Sun, and varies from solar maximum, when sunspot, coronal mass ejection, and flare phenomena are most frequent, to solar minimum, when such activity is relatively infrequent. Solar minimums occurred in 1996 and 2007, while the last solar maximum occurred in 2001. This picture is composed of a SOHO image of the Sun in extreme ultraviolet light for each year of the last solar cycle, with images picked to illustrate the relative activity of the Sun. This would explain why the HF band conditions are what they are...



Another blond joke

Two blonde ladies at a bus stop: The first asks: "Which bus will you take?"
The second says "the five, and you?"
The first one: "the seven."
After 5 minutes comes the seventy five.
The one blonde to the other: "Now we can ride together."

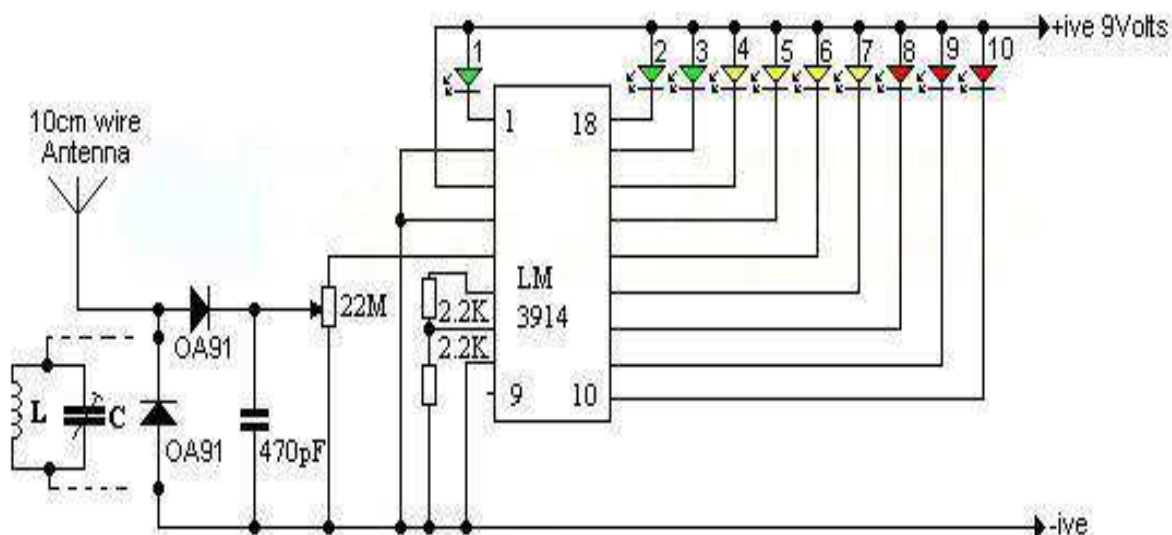

This RF Wave Absorption meter will detect signals between 10cms and 10m away all according to the setting of the 22MegOhm gain adjustment pot and the power of the transmitter. The RF signal is detected across the germanium OA91 diodes and rectified to a d.c. level driving a 10LED driver IC. The LED's are marked 1 to 10 indicating the strength of the detected RF signal. This circuit is ideal for tuning up low power transmitters or locating hidden transmitters. If a specific frequency band is required, replace the OA91 diode that goes to negative with a parallel tuned circuit as indicated. For 27MHz L=10Turns and C=39PF, for 50MHz L=7turns and C=27pF, for 80MHz L=5turns and C=12pF, for 110MHz L=4turns and C=10pF, for 150MHz L=3turns and C=8.2pF All coils are 22SWG wound on a 10mm air former.

CLUB INFORMATION

Postal address PO Box 19937 Sunward Park 1470

Monthly meeting venue

Website <http://www.qsl.net/zs6hvb/>
<http://www.qsl.net/zs6ssc/>

Witwatersrand Rifles HQ
 Cnr Barlow and Cavaleros Str
 Industries West
 Germiston

e-mail zs6hvbinfo@zs6ro.co.za

Bulletins Sunday morning - 145.7875 MHz & 7062 KHz @ 08h45.

Committee

Chairman	Doug Wetton	ZS6BXU	011-680-4906
Vice Chairman	Frank van Wensveen	ZS6TMV	082-294-2648
Secretary/Treasurer	Berridge Emmett	ZS6BFL	011-893-1291
Repeater/Packet/Technical	Ton van Dijk	ZS6ANA	011-432-5494
Shacknews Editor	Berridge Emmett	ZS6BFL	011-893-1291
Shacknews Printing	Harry Lautenbach	ZS6LT	011-888-5362
Webmaster	Yvonne van Dijk	ZR6TBL	011-432-5494

Repeater

145.1875 MHz input

145.7875 MHz output

Linked on a Sunday morning during bulletin time to 70 cm - 438.850 MHz