



HIGHVELD AMATEUR RADIO CLUB

SHACKNEWS

PO Box 19937 Sunward Park 1470

SEPTEMBER 2007

Website <http://www.qsl.net/zs6hvb/>
<http://www.qsl.net/zs6ssc/>

e-mail zs6hvbinfo@zs6ro.co.za

Sunday morning BULLETINS - 145.7875 MHz & 7062 KHz @ ±08h45.

COMMUNICATION IS THE NAME OF THE GAME

Meeting The AGM was held on 1st September 2007 and the committee remains the same for the new club year (See footer). It was decided to keep the subs at the same amount as the previous year – R100.00. As of today, 19th September 2007, nine members have paid their subs.
The repeater maintenance was discussed and it was requested that when this has to be done that a group of us go there. A show of force so to speak.
The next meeting will again be held at the Wits Rifles HQ in Germiston on 6th October. See you there.

SSC Meeting A fair number of members were present at the qth of Berridge and Sandra and the weather allowed all of us to sit outside. Frank, ZS6MER, brought along his NVIS antenna and this was set up to see how it worked. Thanks to Sandra and Sylvia and others brought along all the nice goodies to eat. The next meeting will be at Doug and Merle's QTH on 13th October.

---oooOOOooo---

Teacher: Ted, if your father has R10 and you ask him for R6, how much would your father still have?

Ted: R10.

Teacher: You don't know Maths.

Ted: You don't know my father!

Mother: David, come here.

David: Yes, mum.

Mother: You really disappoint me. Your results are getting worse.

David: But I will only get my report book tomorrow.

Mother: I know that, but I'm going to Hong Kong tomorrow so I'm scolding you now.

Father: Why did you fail your Mathematics Test?

Son: On Monday, teacher said $3 + 5 = 8$

Father: So?

Son: On Tuesday, she said $4 + 4 = 8$. On Wednesday, she said $6 + 2 = 8$.

If she can't make up her mind, how do I know the right answer?

Chairman:	Doug Wetton	ZS6BXU	011-680-4906
Vice Chairman	Frank van Wensveen	ZS6TMV	011-942-3657
Secretary / Treasurer:	Berridge Emmett	ZS6BFL	011-893-1291
Repeater/Packet Radio/Technical	Ton Van Dijk	ZS6ANA	011-942-3657
Shacknews Editor:	Berridge Emmett	ZS6BFL	011-893-1291
Shacknews-Print & Posting:	Harry Lautenbach	ZS6LT	011-888-5362
Website Manager	Yvonne Van Dijk	ZR6TBL	011-942-3657

Girl: Do you love me?
 Boy: Yes Dear.
 Girl: Would you die for me?
 Boy: No, mine is undying love

Man: How old is your father?
 Boy: 1 year older then me
 Man: How can that be?
 Boy: He became a father only when I was born

---oooOOOooo---

Two microphone preamps

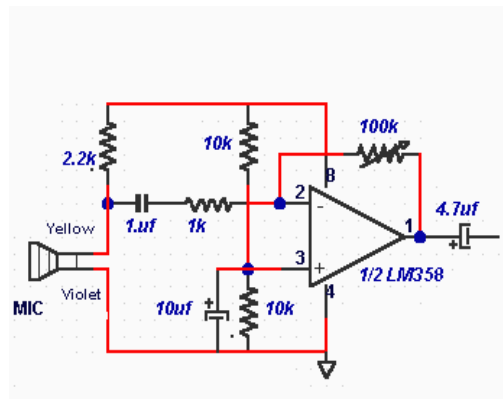
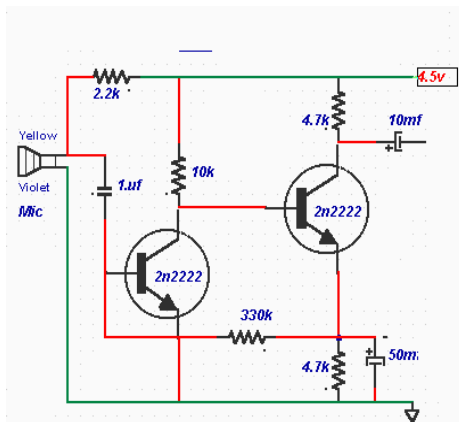

---ooo000ooo---

SMART ANSWER 1

A truck driver was driving along on the freeway. A sign comes up that Reads, " Low Bridge Ahead."
 Before he knows it, the bridge is right ahead of him and he gets stuck under the bridge. Cars are backed up for miles.
 Finally, a police car comes up. The cop gets out of his car and walks to the truck driver, puts his hands on his hips and says, "Got stuck, huh?"
 The truck driver says, "No, I was delivering this bridge and ran out of gas."

SMART ANSWER 2

It was mealtime during a flight on Hooters Airline.
 "Would you like dinner?" the flight attendant asked John, seated in front.
 "What are my choices?" John asked.
 "Yes or no," she replied.

Chairman:	Doug Wetton	ZS6BXU	011-680-4906
Vice Chairman	Frank van Wensveen	ZS6TMV	011-942-3657
Secretary / Treasurer:	Berridge Emmett	ZS6BFL	011-893-1291
Repeater/Packet Radio/Technical	Ton Van Dijk	ZS6ANA	011-942-3657
Shacknews Editor:	Berridge Emmett	ZS6BFL	011-893-1291
Shacknews-Print & Posting:	Harry Lautenbach	ZS6LT	011-888-5362
Website Manager	Yvonne Van Dijk	ZR6TBL	011-942-3657

Rejuvenating dead NiCads

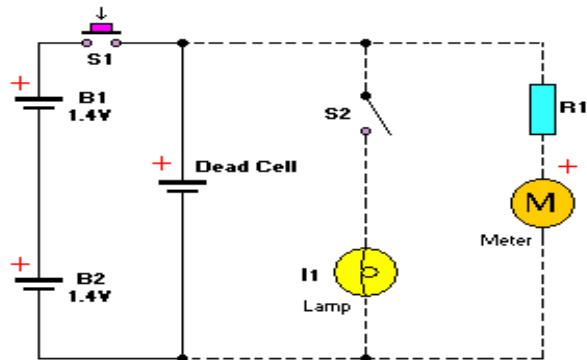

Shown is a schematic diagram of a simple circuit that can be used to dissolve the whisker formation that prevents nickel-cadmium batteries from receiving a charge. The circuit consists of nothing more than two fully charged, series connected NiCad batteries (B1 and B2) and a switch (S1). Nickel cadmium batteries were used for the source because they can deliver lots of current. For example, AA-size cells can deliver a continuous current of 0.5 amperes. Switch S1 allows you to control the amount of time that rejuvenating power is applied to the sleeping battery. When S1 is closed, a jolt of current of sufficient magnitude is sent through the battery so as to cause the tiny whiskers (shorts) within to open. Also, if the dead battery has become reverse-polarized, the polarity is also corrected by the harsh treatment. The dashed portion of the circuit is optional and can be included to allow you to monitor/test the circuit's operation. Including the resistor (R1) and meter (M1) in the circuit eliminates the need for an external meter. Adding a second switch (S2 in Fig. 1) and a flashlight lamp (I1) enables you to monitor the battery's voltage under load. By removing the dead battery and closing S1 and S2 at the same time, you can test the live batteries under load.

---ooo000ooo---

Wisdom of Larry the Cable Guy:

1. A day without sunshine is like night.
2. On the other hand, you have different fingers.
3. 42.7 percent of all statistics are made up on the spot.
4. 99 percent of lawyers give the rest a bad name.
5. Remember, half the people you know are below average.
6. He who laughs last thinks slowest.
7. Depression is merely anger without enthusiasm.
8. The early bird may get the worm, but the second mouse gets the cheese in the trap.
9. Support bacteria. They're the only culture some people have.
10. A clear conscience is usually the sign of a bad memory.
11. If you think nobody cares, try missing a couple of payments.
12. How many of you believe in psycho kinesis? Raise my hand.

Chairman:	Doug Wetton	ZS6BXU	011-680-4906
Vice Chairman	Frank van Wensveen	ZS6TMV	011-942-3657
Secretary / Treasurer:	Berridge Emmett	ZS6BFL	011-893-1291
Repeater/Packet Radio/Technical	Ton Van Dijk	ZS6ANA	011-942-3657
Shacknews Editor:	Berridge Emmett	ZS6BFL	011-893-1291
Shacknews-Print & Posting:	Harry Lautenbach	ZS6LT	011-888-5362
Website Manager	Yvonne Van Dijk	ZR6TBL	011-942-3657

13. OK, so what's the speed of dark?
14. When everything is coming your way, you're in the wrong lane.
15. Hard work pays off in the future. Laziness pays off now.
16. How much deeper would the ocean be without sponges?
17. Eagles may soar, but weasels don't get sucked into jet engines
18. What happens if you get scared half to death, twice?
19. Why do psychics have to ask you for your name?
20. Just remember -- if the world didn't suck, we would all fall off.

---ooo000ooo---

Wild life



Berridge ZS6BFL

Chairman:	Doug Wetton	ZS6BXU	011-680-4906
Vice Chairman	Frank van Wensveen	ZS6TMV	011-942-3657
Secretary / Treasurer:	Berridge Emmett	ZS6BFL	011-893-1291
Repeater/Packet Radio/Technical	Ton Van Dijk	ZS6ANA	011-942-3657
Shacknews Editor:	Berridge Emmett	ZS6BFL	011-893-1291
Shacknews-Print & Posting:	Harry Lautenbach	ZS6LT	011-888-5362
Website Manager	Yvonne Van Dijk	ZR6TBL	011-942-3657